

INSTRUCTION MANUAL
DIGITAL PROGRAMMABLE POWER SOURCE
MODEL DPS V 20-1

KIKUSUI ELECTRONIC CORPORATION

11/7 . . 82.5.24

823262

On Power Supply Source, it is requested to replace the related places in the instruction manual with the following items.

(Please apply the item of mark.)

- Power Supply Voltage: to _ _ _ _ _ V AC
- Line Fuse: to _ _ _ _ _ A
- Power Cable: to 3-core cable (See Fig. 1 for the colors.)

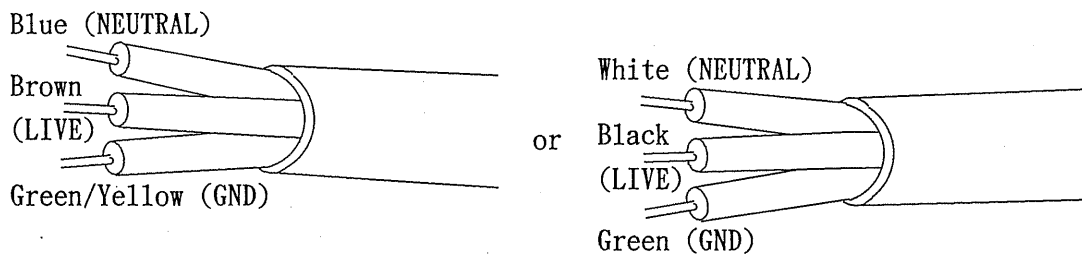

Fig. 1

Please be advised beforehand that the above matter may cause some alteration against explanation or circuit diagram in the instruction manual.

- * AC Plug: In case of Line Voltage 125V AC or more, AC Plug is in principle taken off and delivered, in view of the safety.
(AC Plug on 3-core cable is taken off in regardless of input voltages.)
TO connect the AC plug to the AC power cord, connect the respective pins of the AC plug to the respective core-wires (LIVE, NEUTRAL, and GND) of the AC power cord by referring to the color codes shown in Fig. 1.

Before using the instrument, it is requested to fix a suitable plug for the voltage used.

90.11.14

905181

TABLE OF CONTENTS

	PAGE
1. GENERAL	1
2. SPECIFICATIONS	2
3. OPERATION METHOD	4
3.1 Description of Front Panel	4
3.2 Description of Rear Panel	4
3.3 Pins of Control Input Connector	7
3.4 Input/Output Control Signals	8
3.5 Timing Charts of Control Signals	9
3.6 Preparations for Operation	13
3.7 Example of Control	14
3.8 Actual Example of Control	17
4. OPERATING PRINCIPLE	18
4.1 Circuit Structure	18
4.2 Operation Description	19
5. APPLICATION	22
5.1 Examples Controls of DPS Series	22
5.2 Examples of Use of DPS Series	23
6. MAINTENANCE	25
6.1 Layout of Components	25
6.2 Adjusting Procedures	27

1. GENERAL

The DPS V 20-1 Digital Programmable Power Source is a bipolar constant-current constant-voltage power source designed for use in automatic test systems. Its output voltage can be controlled with an external signal.

Voltage setting can be done with two ranges: 0 to ± 1.999 V (1 mV resolution) and 0 to ± 19.99 V (10 mV resolution). Voltage setting, including polarity setting, can be controlled with a 14-bit signal.

The output voltage is controlled with a TTL level negative logic BCD signal. When the required data is ready, a strobe signal turns on. The data is stored in an internal register and at the same time the output voltage swiftly and accurately shifts to the preset values.

Compliance can be set for a range of approximately $\pm(50$ mA to 1 A) using a manual knob on the front panel. When the set value is reached, the operation changes to the constant-current mode.

The output section is electrically isolated from the input control section. Addresses can be specified as required. A multiple-channel power source system can be easily set-up, making this instrument extremely versatile.

This instrument can be used as a power source for semiconductor testing, IC testing, circuit board testing as well as a regular power source for many electronic devices. When used in conjunction with a Kikusui GP-IB Interface, this instrument is compatible with many types of computers and can be used in automatic measuring systems.

2. SPECIFICATIONS

Instrument name: Digital Programmable Power Source

Model No. : DPS V 20-1

Output section

Type: Bipolar constant-voltage constant-current transfer type

Voltage: 0 to ± 19.99 V

Ranges: Two ranges of 2 V and 20 V

Resolutions: 1 mV and 10 mV

Setting accuracy: 0.03% + 0.03% of range (at 25°C (77°F))

Ripple and noise: 300 μ V rms or less (at 10 Hz - 1MHz)

Programming noise: ± 50 mV peak or less (at rear terminal, 20 V range)

Load regulation: 0.006% of range + 500 μ V or less (at rear terminal), for 0 - 100% load change

Line voltage regulation: 0.002% or less, for $\pm 10\%$ line voltage change

Response speed: 500 μ sec or faster, for "-" maximum voltage to "+" maximum voltage within the range

Output current: 1 A maximum

Setting: Manual, approx. $\pm(50$ mA to 1 A)

Control section

Input/output signal: TTL level

Control signals

Data	Polarity	1 bit	
	Voltage	13 bits	(BCD)
Strobe		1 bit	(edge)
Address		4 bits	
<u>Standby</u>		1 bit	
Range		2 bits	
Set		1 bit	
Direct zero		1 bit	
Direct standby		1 bit	
Data clear			(except polarity)

Output signals

Address coincidence	
Data accept (DAC)	
Error flag	o Data overflow
	o Range inconformity
Thermal down	
Constant-current transfer (CC)	
<u>Ready</u>	

Ambient temperature: 5°C to 35°C (41°F to 95°F)

Withstanding voltage of input/output circuit: 500 V maximum

Power requirements: 117 V ±10%, 50/60 Hz AC, approx. 100 VA (with full load)

Dimensions: 210W × 90H × 370D mm (8.3W × 3.6H × 14.6D in.)
(Maximum dimensions): 220W × 100H × 400D mm (8.7W × 4.0H × 15.8D in.)

Weight: Approx. 8.7 kg (19 lbs.)

Accessories: Instruction manual 1 copy
50P plug 1

V20-1 KIC 117V

823260

3. OPERATION METHOD

3.1 Description of Front Panel (See Figure 3-1.)

① POWER switch:

The power switch (circuit breaker) is a rocker type. The instrument power is turned on as the ON side is depressed.

② OUTPUT terminals:

The output terminals (binding posts) provide an output of $\pm(0$ to 20 V, 1 A). The white terminal is an L-side terminal. These terminals are connected in parallel with the output terminals on the rear panel.

③ CURRENT:

The current limiting knob has a range of approximately 50 mA to 1 A. When the current has reached the limit value, the operation is transferred into the constant-current mode.

④ DISPLAY lamps:

These LEDs indicate the operating state of the instrument.

3.2 Description of Rear Panel (See Figure 3-2.)

⑤ ADDRESS switches:

These slide switches are for address settings of individual instruments. When the controller's address line is H.H.H.H or the control line is open, all attached power supplies will be controlled regardless of their address settings.

⑥ Fan motor:

Cooling fan motor.

⑦ Power cord:

To be connected to an AC line outlet of correct voltage and frequency.

⑧ Terminal block

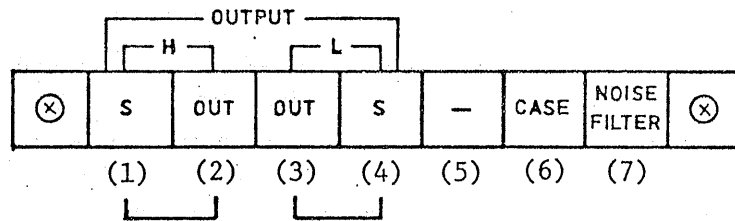

- (1) When no sensing is required, short-circuit this sensing terminal (H side) to terminal (2).
- (2) Output terminal (H side)
- (3) Output terminal (L side)
- (4) When no sensing is required, short-circuit this sensing terminal (L side) to terminal (3).
- (6) Case ground terminal
- (7) Center power line noise filter terminal. If this terminal is connected to the case ground terminal, a current leak occurs although the filtering effect is improved. Connection of this terminal will vary with usage.

⑨ Connector

For connection of control input (50-pin connector)

See section 3.3 Pins of Control Input Connector.

823268

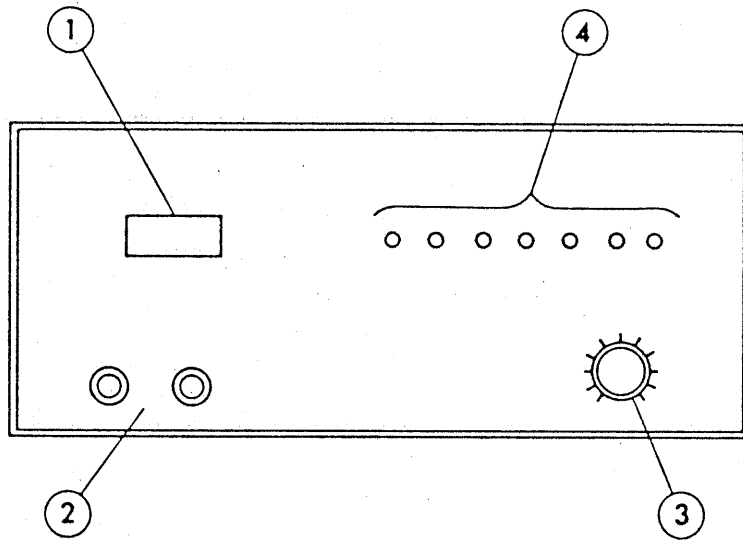

Figure 3-1. Front panel

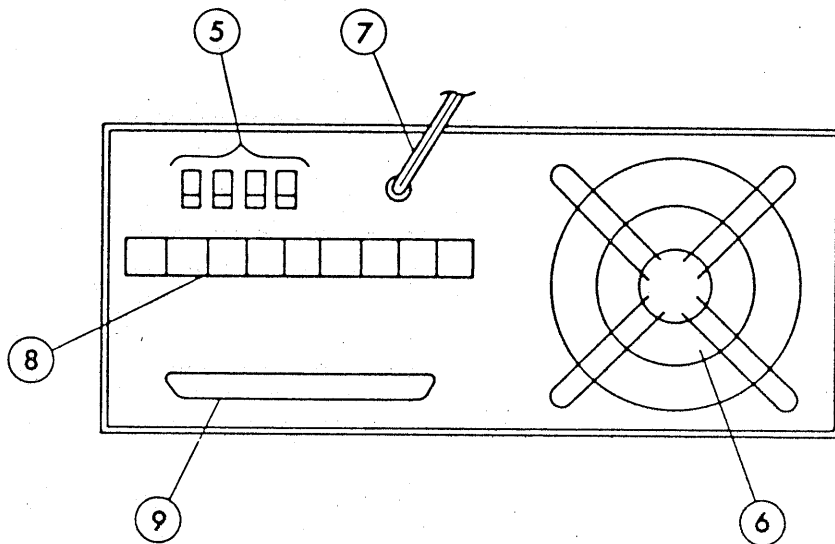

Figure 3-2. Rear panel

3.3 Pins of Control Input Connector

1	STROBE	26	1	} LSD
2		27	2	
3		28	4	
4		29	8	
5		30	1	}
6		31	2	
7		32	4	
8	<u>STAND BY</u>	33	8	}
9		34	1	
10		35	2	}
11		36	4	
12		37	8	
13		38	1	}
14	DATA CLEAR	39		
15	DIRECT STAND BY	40		}
16	DIRECT ZERO	41		
17	2 ⁰ } RANGE	42	THERMAL DOWN	}
18	2 ¹ }	43	DAC	
19	2 ⁰ } ADDRESS	44	2 ² }	}
20	2 ¹ }	45	2 ³ }	
21	C C	46	POLARITY	
22	POWER ON SIG	47	ERROR	
23	+5 V OUT	48	<u>READY</u>	
24	ADDRESS COINCIDENCE	49	SET	
25	GND	50	GND	

3.4 Input/Output Control Signals

Example: TTL level

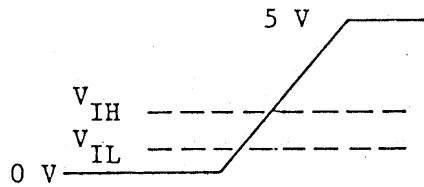

V_{IL} : 0.8 V max.

V_{IH} : 2 V min.

I_{IL} : -1.6 mA max. ($V_{IL}=0.4$ V)

I_{IH} : 40 μ A max. ($V_{IH}=2.4$ V)

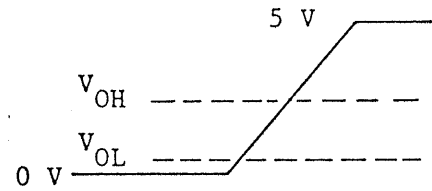

V_{OL} : 0.4 V max.

V_{OH} : 2.4 V min.

Output voltage control signal	At L level	Operation (1)			
Polarity	At H level	+			
	At L level	-			
Strobe (data)	H \rightarrow L \rightarrow H	Operation (with edge)			
Address	Level	Coincidence signal			
Standby	At H level	Standby ON			
	At L level	Standby OFF			
Range	Level	* (R: Ranges to be used for respective models)			
	2 ¹		2 ⁰	strobe (data)	
	H		H		$R \leq 1$ [V]
	H		L		$1 < R \leq 10$ [V]
	L		H		$10 < R \leq 100$ [V]
	L		L		$100 < R \leq 1000$ [V]
Set	At L level	Standby release			
Direct zero	At L level	Output is zero irrespective of address.			
Direct standby	At L level	Standby ON irrespective of address.			

Address coincidence	L level	Coincidence of address code
DAC	 (pulse)	Reception of strobe
Error set	L level	Data overflow, invalid range setting
Thermal down	Relay makes contact	Instrument overheating
CC (constant-current transfer)	L level	Constant-current state
Ready	H level	
Data clear (10 μ sec or over)	L level	Clears resistor

* Example: For the model with 2 V range, 2¹ and 2⁰ becomes H and L.

3.5 Timing Charts of Control Signals

(1) When power is ON

o When the SET signal and STANDBY signal are L

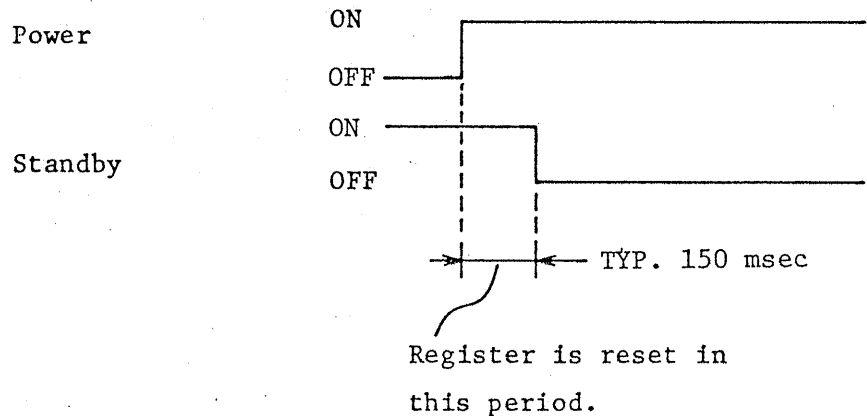

- o When the SET signal is H and the STANDBY signal is L

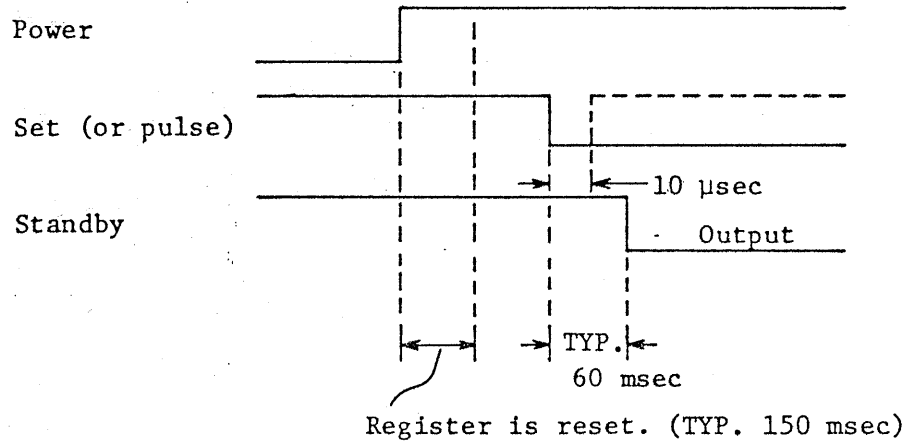

(2) Data, polarity, strobe and address

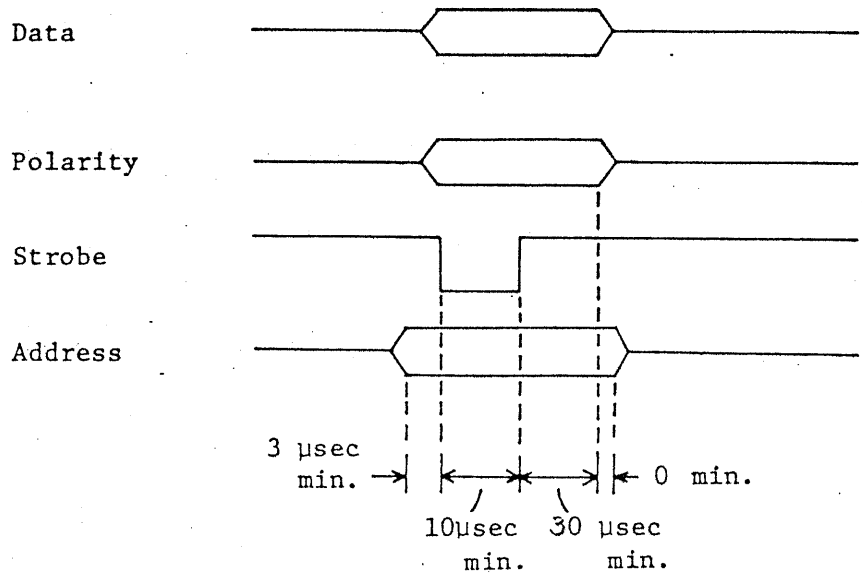

(3) Standby switch

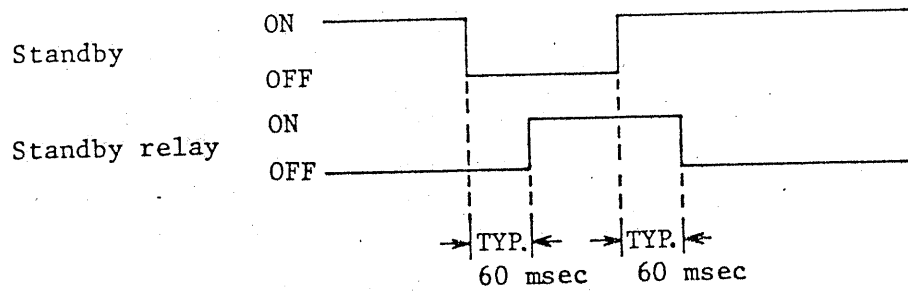

Electromagnetic relay is used for standby switch.

(4) $\overline{\text{Ready}}$

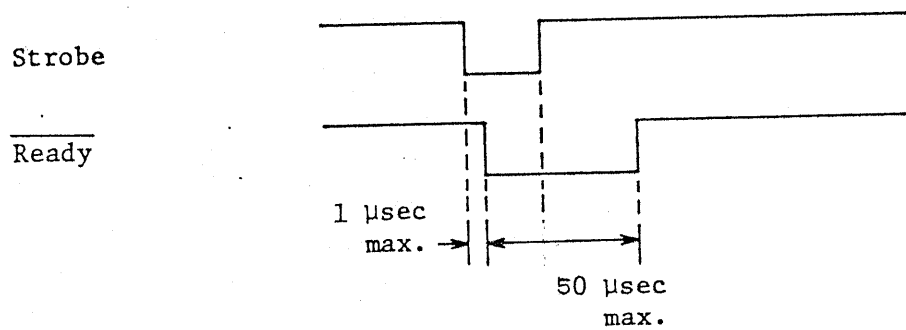

(5) Address coincidence

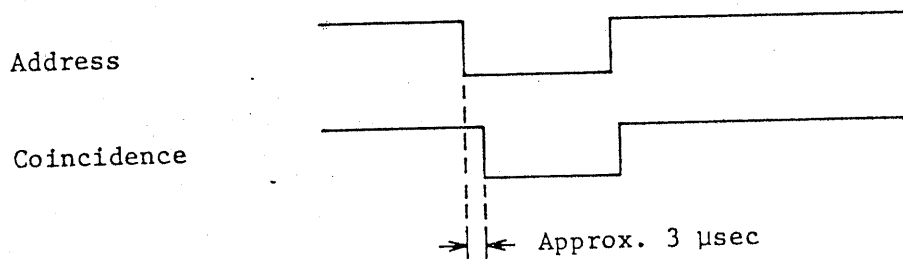

823274

- (6) Error
 - o Invalid range setting
 - o Data overflow

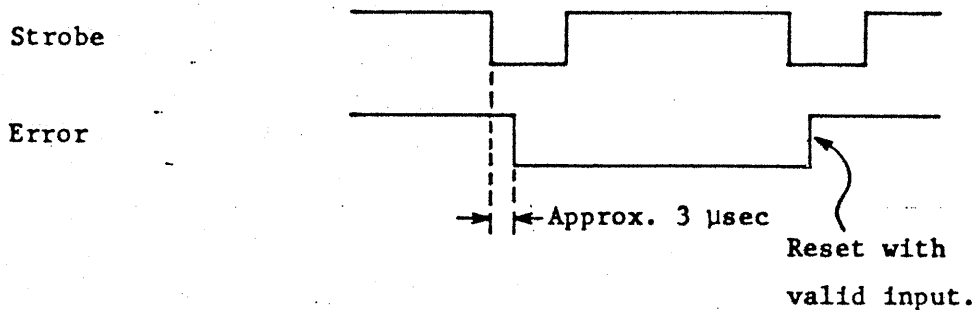

- (7) DAC (data accept)

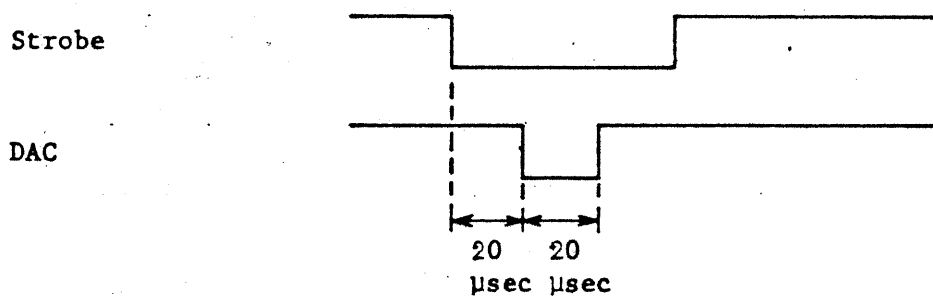

- (8) Range

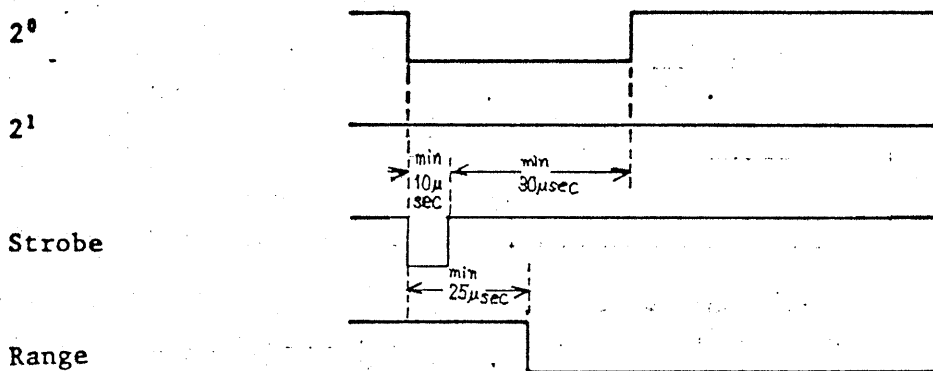

3.6 Preparations for Operation

- (1) Connect the power cord to an AC line outlet of the correct voltage and frequency.
- (2) Turn on the power switch.
- (3) The instrument is ready for operation several minutes after turning on the power. When high accuracy is required, allow a stabilization period of 30 minutes or more.
- (4) Enter data and set the initial values.
- (5) Adjust the current limit knob to the required value.
- (6) Apply the Set signal.
- (7) Release the standby state. Note that relay chattering and overshoots may occur when the standby state is released.
 - o The Set signal needs only to be applied once each time the power is turned on.
 - o The direct standby and zero signals can be controlled independently of address specification. The direct zero signal is electrically switches the output signal to zero volts. The standby signal mechanically disconnects output signal. When the direct zero or standby signal is removed, the original state is automatically restored.
 - o If the controller's address setting is HHHH (0000) or if the address input is open, all attached power supplies will be controlled regardless of their individual addresses.

Note: No overshoots or undershoots are caused when the voltage varies in the same polarity. However, slight overshoots or undershoots may be caused if the voltage is small and both polarity and data are changed at the same time.

3.7 Example of Control

- o Although various input/output signals are available, output voltage alone can be controlled only with data and strobe signals.
- (1) For multi-channel operation, address setting on each instrument's rear panel must be set. The control code is a 4-bit binary negative logic signal (pin numbers 19, 20, 44 and 45).
- (2) For a model which has different ranges, a range specification is required (pin numbers 17 and 18). The range specification is done with a 2-bit structure. If a fixed-range is required, this can be done by means of electrical connections.

The ranges are written with a strobe signal in the instrument. If the range setting is invalid, the data cannot be written. Be sure to check the code before setting the ranges. The range codes are as follows:

When the maximum value is	2^1	2^0
0.1 to less than 1	0	0
1 to less than 10	0	1
10 to less than 100	1	0
100 to less than 1000	1	1

Of the 2-bit negative logic code, "1" is the L level. The V series is in the [V] unit and the C series is in the [mA] unit.

Examples:		2^1	2^0
V 20-1	2 V range	0	1
	20 V range	1	0
C 20-1	100 mA range	1	0
	1 A range	1	1

- (3) When setting is not required for a model which has the Set signal feature, make electrical connections so that the bit signal is for "1" (L level). When the power is turned on, an output signal of 0 V DC will be produced. To operate this model, set it in the "1" state after initial set up. Alternately, a negative-going pulse signal ($\bar{1}$) may be applied (pin number 49).
- (4) Set data with a negative logic BCD signal and apply a strobe signal.

Although control at the TTL level is most recommendable, control may be done with relays, transistors, switches, etc. (pin number 1 (strobe), pin numbers 26 - 41 (data)).

- (5) For standby control (isolation with output relay)

The standby state is reset as the level is changed from H to L. It is set as the level is changed from L to H. (Edge operation) (Pin number 8)



The standby state is controlled in the addressed state.

- (6) Direct standby (If not required, set OPEN or H) (Pin number 15)

This standby state is controlled irrespective of address. This standby state is reset by the H level and set by the L level. (Level operation)

- (7) Direct zero (If not required, set OPEN or H) (Pin number 16)

This signal is for DC ON/OFF control of the output voltage. When this signal is at the L level, the output voltage becomes zero. This signal does not clear the contents of the register and, therefore, the previous set voltage is restored when this signal is returned to the H level.

- (8) Data clear (If not required, set OPEN or H) (Pin number 14)

This is the clear bit signal of the data register. When this signal is set at the L level, the contents of the register are cleared and the output becomes zero. (A negative-going pulse may be used instead.)

3.8 Actual Example of Control

To obtain an output with varied steps

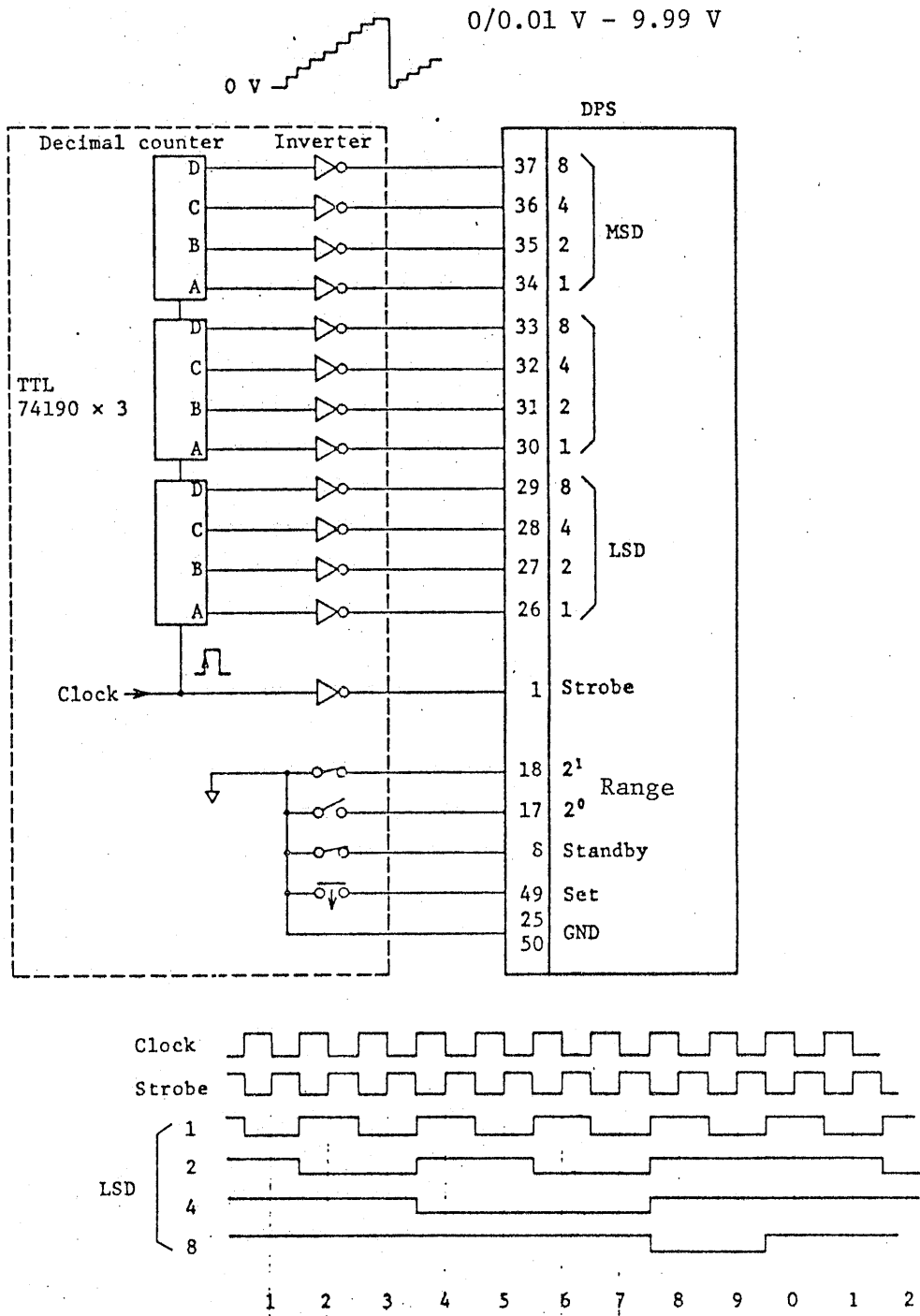

823280

4. OPERATING PRINCIPLE

4.1 Circuit Structure

The circuit structure of this instrument is shown with a block diagram in Figure 4-1.

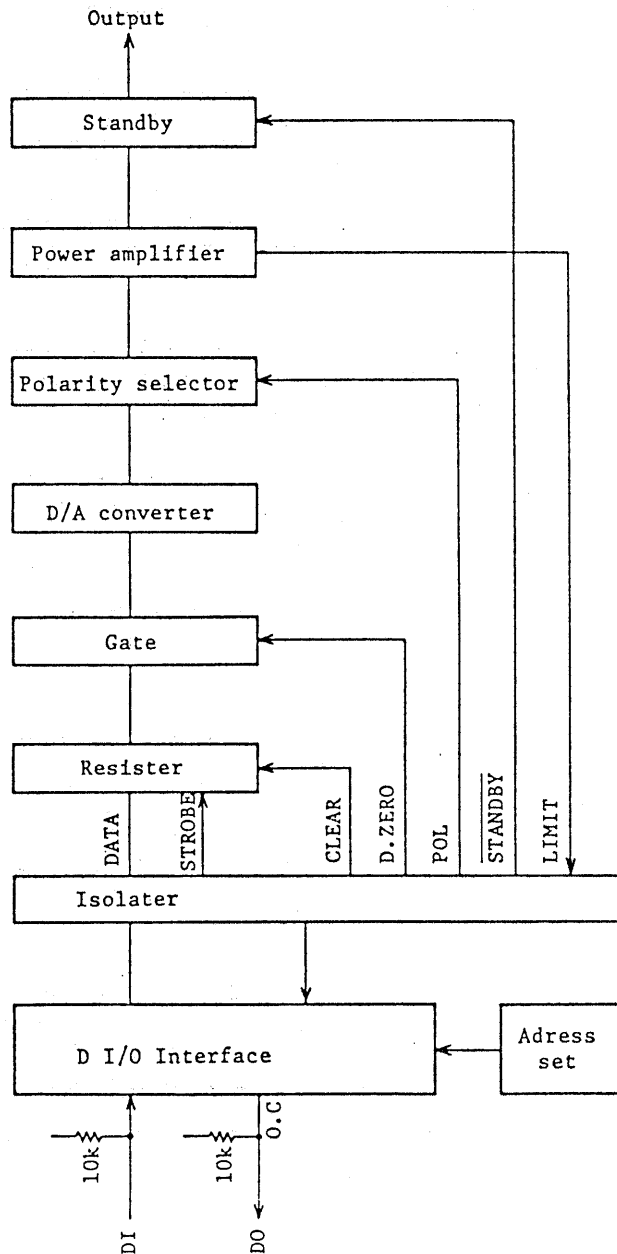

Figure 4-1

4.2 Operation Description

The input/output Logic Level signal is pulled up by a resistor (10 k Ω). Data entered at the TTL level is subjected to a buffer effect at the D I/O interface section, it is isolated with a photocoupler, and then it is stored in the register.

The Strobe signal is passed on when address "0" is specified (or when open) or when the address set at the instrument (main unit) conforms with the specified address. The Strobe signal then is fed via the isolator to the register to let the data stored in the register. The stored data is maintained, until the next Strobe signal is applied, even when the input is varied.

The Data Clear signal clears the register, making all bits "0". The stored data is fed via a gate to the D/A converter. The gate is for the direct zero signal, and is capable of making all bits "0" temporarily without clearing the register.

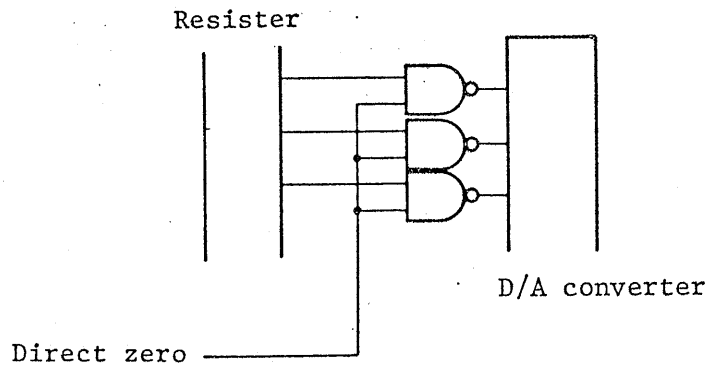

For the gate, a NAND gate is used as the D/A converter input is a complimentary type. When the gate is closed, its output becomes the H level.

The digital signal is converted into an analog signal by the D/A converter, the polarity of the analog signal is selected by the Polarity signal, and the resultant signal is fed to the output amplifier.

The Polarity Selector, being controlled with the Polarity signal and an FET switching circuit, selects between polarity inversion and non-inversion.

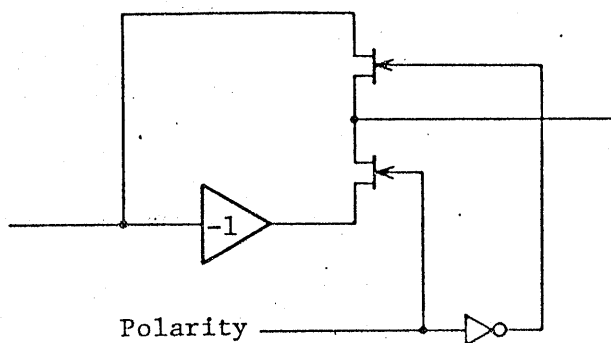

To reduce the effects of the ON resistance of the FET switch circuit, the voltage is received with a voltage follower and its output is fed to the output amplifier.

The power amplifier consists of an IC (initial stage), transistor circuits, and control transistors. It is a high speed, high stability, high accuracy operational amplifier.

The output current limiter monitors the voltage developed across the resistor inserted in series with the load circuit. When the monitored voltage has exceeded the preset voltage, the limiter circuit makes up a closed loop with the final stage of the constant-voltage amplifier. The instrument operation switches to the constant-current mode and remains in this mode. This mode is indicated on the front panel. When in this mode, the output is delivered through the isolator.

This instrument has a motor-driven fan to cool the control transistors of the output section.

823283

5. APPLICATION

5.1 Examples of Controls of DPS Series

(1) Direct control with CPU

CPU: Various controllers (computers, digital equipment, etc.)

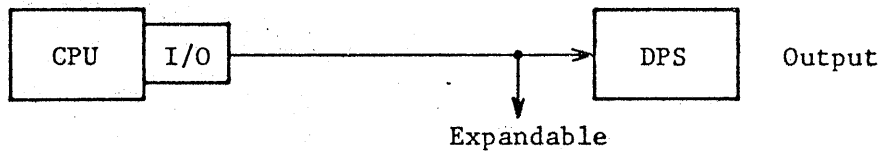

(2) Control with standard interface

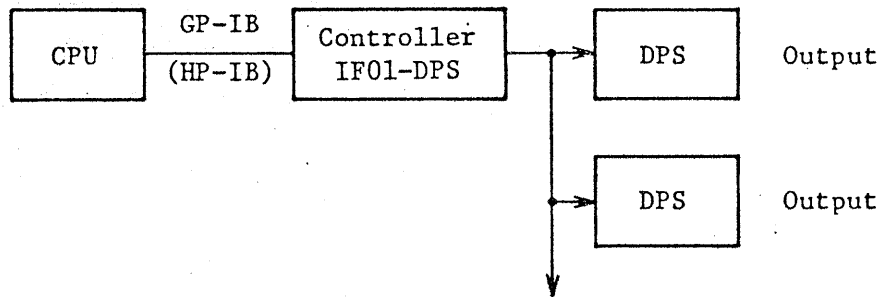

Up to 15 units can be controlled.

(3) Function generation with KIKUSUI MODEL CM01-DPS

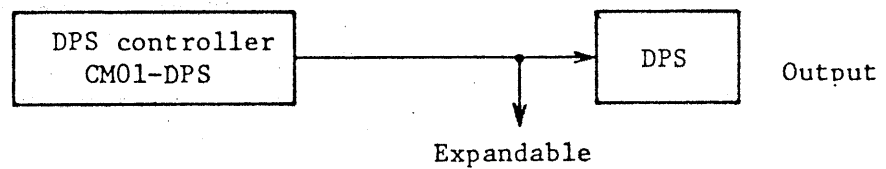

Non-volatile memory of 64 steps available

(4) Remote control

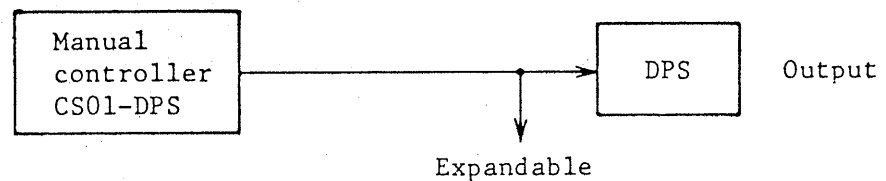

5.2 Examples of Use of DPS Series

(1) For programmable control of generator

Oscillating frequencies of a frequency generator can be program-controlled. For example, apply the DPS output to the VCG (voltage-controlled generator) terminal of a function generator.

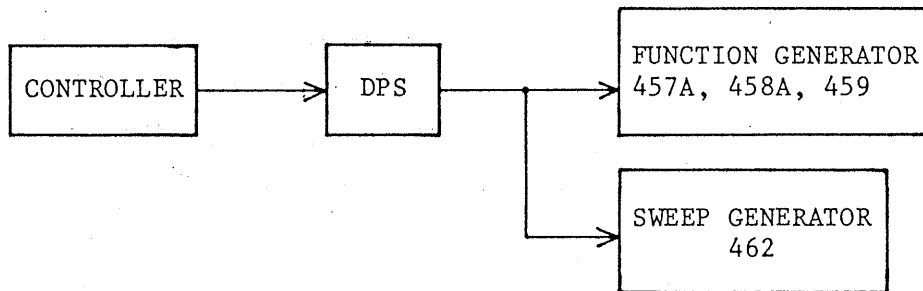

Output amplitude control also is programmable. For example, apply the DPS output to the VCA (voltage-controlled amplitude) terminal of a function generator.



(2) To use as a simple D/A converter

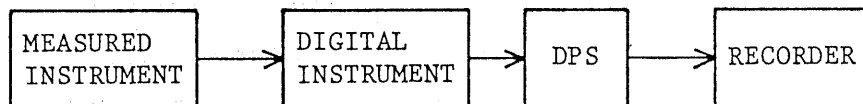

- (3) To use as a signal source (an example for impurity density measurement of semiconductors)

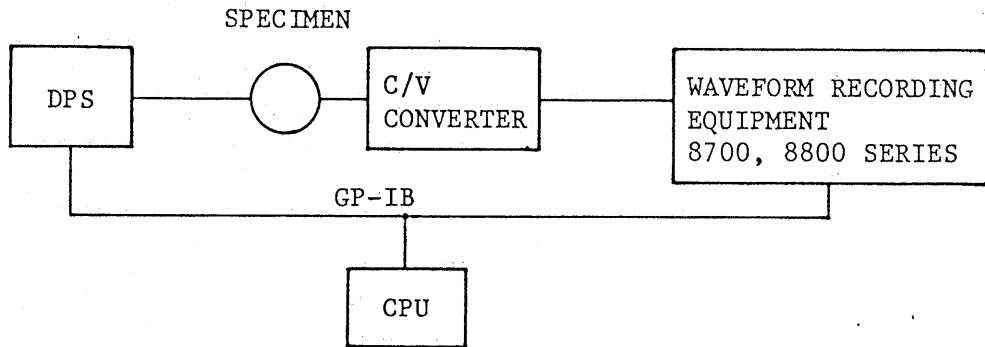

- (4) For digital control of outputs of large ratings

For DC voltage/current:

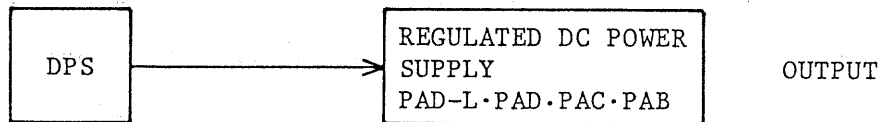

(Minor modification is required.)

For bipolar power:

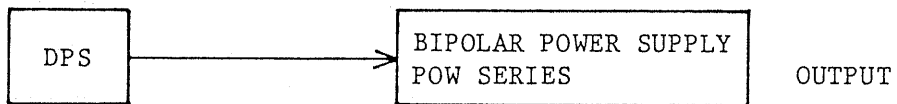

For constant-current load device:

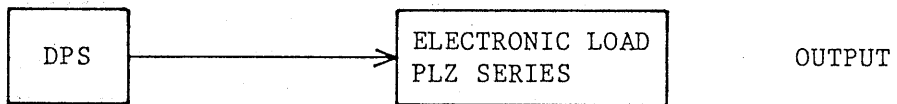

6. MAINTENANCE

6.1 Layout of Components

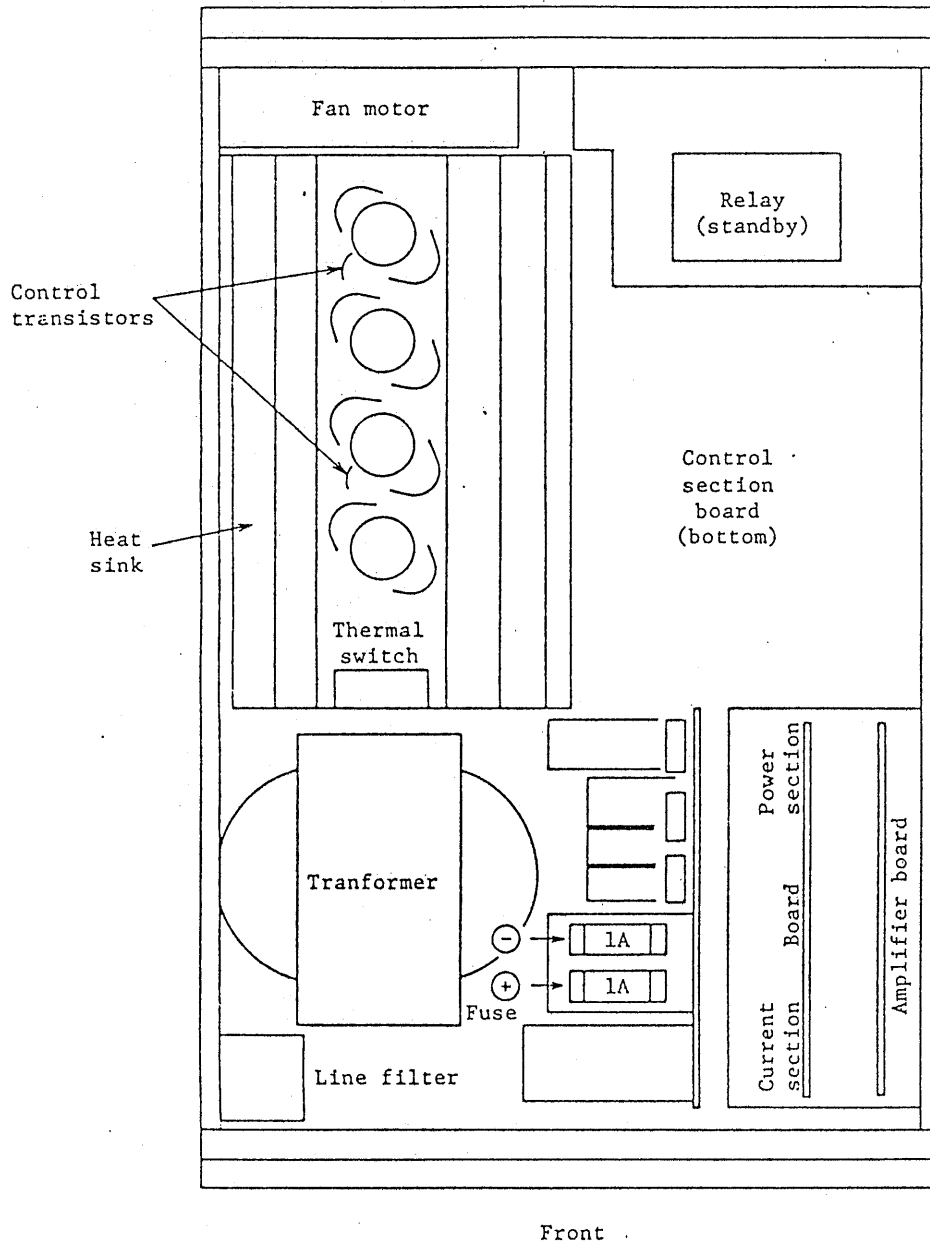

Figure 6-1 (Top view)

Layout of potentiometers

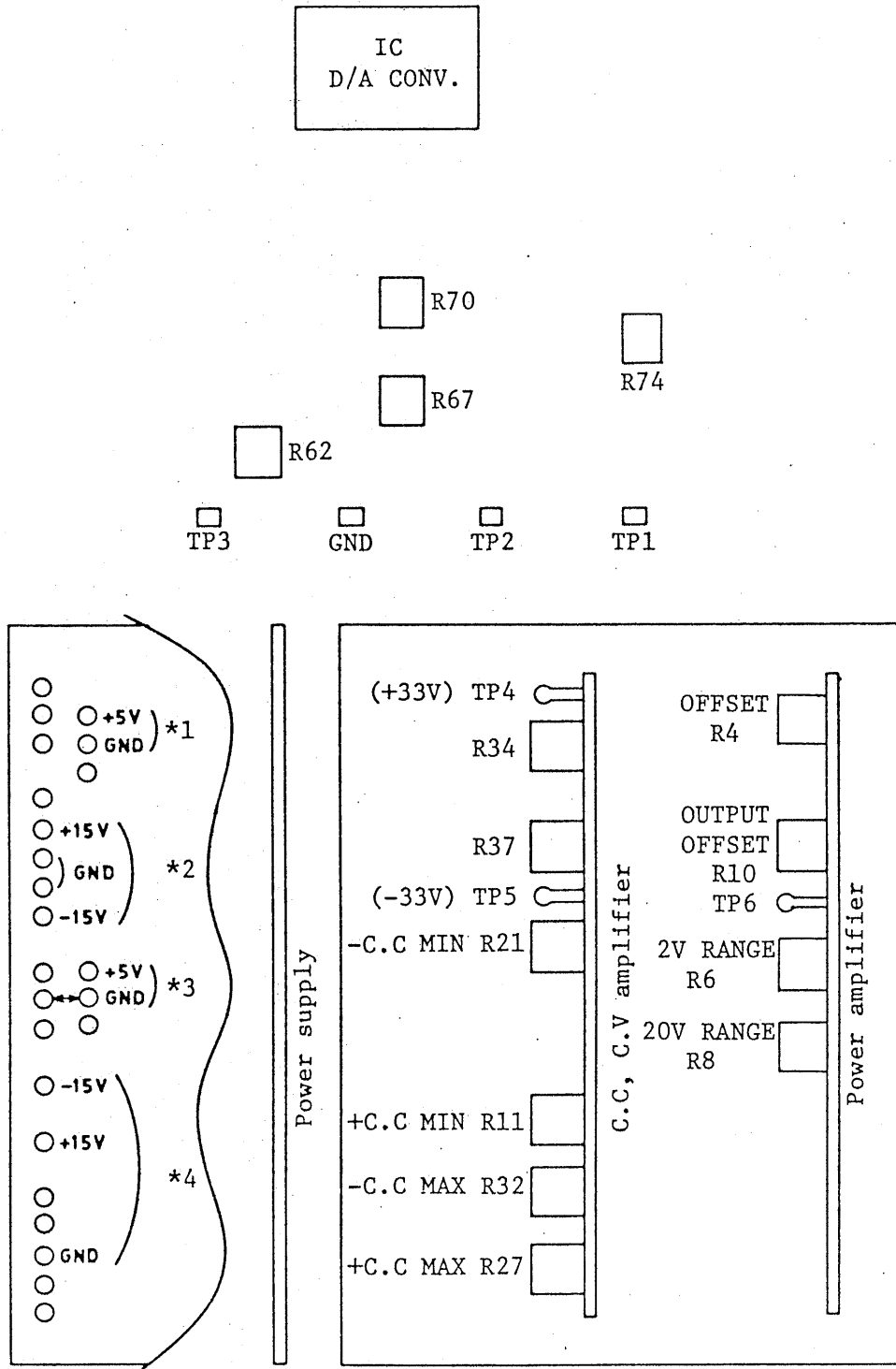

Figure 6-2

6.2 Adjusting Procedures (See Figure 6-2.)

(1) Check and Adjustment of Supply Voltages

1-1 Check of +15 V and -15 V supplies of control circuit

Each of these supplies employs a 3-terminal fixed-output IC. Connect a voltmeter between control GND terminal and +15 V terminal, and check that the voltage is within 14.2 V to 15.8 V. Connect a voltmeter between control GND terminal and -15 V terminal, and check that the voltage is within -14.2 V to -15.8 V.

1-2 Check of +5 V supply of control circuit

This supply employs a 3-terminal fixed-output IC. Connect a voltmeter between control GND terminal and +5 V terminal, and check that the voltage is within 4.75 V to 5.25 V.

1-3 Check of +15 V and -15 V supplies of power amplifier

Each of these supplies employs a 3-terminal fixed-output IC. Connect a voltmeter between power GND terminal and +15 V terminal, and check that the voltage is within 14.2 V to 15.8 V. Connect a voltmeter between power GND terminal and -15 V terminal, and check that the voltage is within -14.2 V to -15.8 V.

1-4 Check of 5 V supply of interface circuit

This supply employs a 3-terminal fixed-output IC. Connect a voltmeter between interface GND terminal and +5 V terminal, and check that the voltage is within 4.75 V to 5.25 V.

- 1-5 Adjustment of ± 33 V supplies of power amplifier
(CC, CV amplifier board)

Connect a voltmeter between power GND pin No. 4 (L side) and TP4. So adjust potentiometer R34 that the voltmeter reads within 32.5 V to 33.5 V. Connect a voltmeter to TP5 and adjust the potentiometer R37 so that the voltmeter reads within -32.5 V to -33.5 V.

- (2) Offset adjustment of IC

- o Enter data [+0000].

- 2-1 Connect a digital voltmeter between pin 6 (TP1) of MC16 of D/A converter and GND terminal, and adjust potentiometer R74 so that the digital voltmeter reads within ± 20 μ V.
- 2-2 Connect a digital voltmeter between pin 6 (TP2) of MC15 of inverter and GND terminal, and adjust potentiometer R67 so that the digital voltmeter reads within ± 20 μ V.
- 2-3 Connect a digital voltmeter between pin 6 (TP6) of MC1 of power amplifier and GND terminal, and adjust potentiometer R4 so that the voltmeter reads within ± 20 μ V.

- (3) Gain adjustment of D/A converter

Set the range at 2 V (0, 1) or 20 V (1, 0).

Enter data [-0999].

- 3-1 Connect a digital voltmeter between TP6 and GND.
Adjust the potentiometer R70 so that the voltage becomes $+4.995$ V ± 250 μ V.

(4) Power amplifier offset and gain adjustment

- o Set the range at 20 V (1, 0) and enter data [-0000].
- 4-1 Connect a digital voltmeter to the output terminal and adjust the potentiometer R10 so that the voltmeter reads a value within $\pm 50 \mu\text{V}$.
 - o Change data to [-0999].
- 4-2 Adjust the potentiometer R8 so that the output voltage becomes $-9.99 \text{ V} \pm 500 \mu\text{V}$.
 - o Change data to [-1000].
- 4-3 Adjust the potentiometer R58 of the D/A converter section so that the output voltage becomes $-10.00 \text{ V} \pm 500 \mu\text{V}$.
 - o Change data to [+1999].
- 4-4 Adjust potentiometer R62 of the inverter section so that the output voltage becomes $+19.99 \text{ V} \pm 1 \text{ mV}$.
- 4-5 Vary each input data and measure the output voltage to check that it is within the tolerance. If it is not within the tolerance, adjust it with the corresponding potentiometer.
 - o Set the range at 2 V (0, 1) and enter data [-1999].
- 4-6 Adjust the potentiometer R6 so that the output voltage becomes $-1.999 \text{ V} \pm 100 \mu\text{V}$.
- 4-7 Vary each input data and measure the output voltage checking to insure that it is within the tolerance. If it is not within the tolerance, adjust it with corresponding potentiometer again.

823292

(5) Adjustment of output current

Set the output voltage at zero. Connect a slide-wire rheostat and a DC ammeter in series to the output terminals. (Select a slide-wire rheostat of a resistance which will allow a current of 1 ampere or more to flow when the output voltage is applied.)

- 5-1 Turn the current limit knob on the front panel to the extreme counterclockwise position. Enter "-" data to produce the output voltage. Varying the resistance of the rheostat, adjust the potentiometer R21 of the current amplifier so that the operation is transferred into the constant-current mode when the output current is approximately -30 mA.
- 5-2 Turn the current limit knob to the extremely clockwise position. Reduce the resistance of the rheostat and so adjust potentiometer R27 of the current amplifier that the operation is transferred into the constant-current mode when the output current is approximately -1.05 A.
- 5-3 Repeat alternately the procedures of 5-1 and 5-2 so that the best conditions are obtained for both requirements.
- 5-4 Turn the current limit knob on the front panel to the extreme counterclockwise position. Enter "+" data to produce the output voltage. Varying the resistance of the rheostat, adjust the potentiometer R11 of the current amplifier so that the operation mode will switch to the constant-current mode when the output current is approximately +30 mA.
- 5-5 Turn the current limit knob to the extreme clockwise position. Reduce the resistance of the rheostat and adjust the potentiometer R32 of the current amplifier so that the operation switches to the constant-current mode when the output current is approximately +1.05 A.

5-6 Repeat alternately the procedures of 5-4 and 5-5 so that the best conditions are obtained for both requirements.